

The ability to provide a jet purge adapter to a piston type sampling valve ensures optimal retrieval of a representative, contamination free sample. The DPJ type sampler in fixed volume configuration allows purging of the sample outlet of the valve to eliminate dead volume in addition to a fixed sample volume. The jet purge adapter has two flow paths. The first flow path allows the product to flow into the sample bottle and the second flow path enables the jet purge adapter to be purged with an inert gas.

**1 OPERATION/FUNCTION**

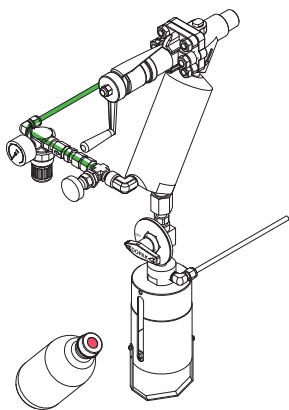

**0 - off**

Provide a new septum on your sample bottle. Insert the bottle, with cap and septum into the sleeve until the septum is pierced by the needles. Put the bottle retaining clip in place.

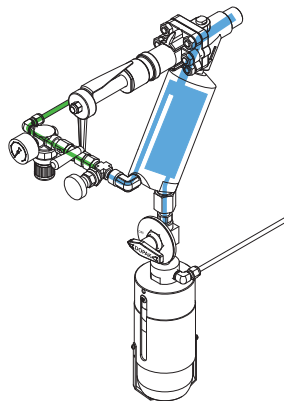

**1 - fill**

Open the piston valve allowing the product to flow into the sample chamber. The fixed volume chamber and process pressure determines the amount of sample. Close the piston valve.

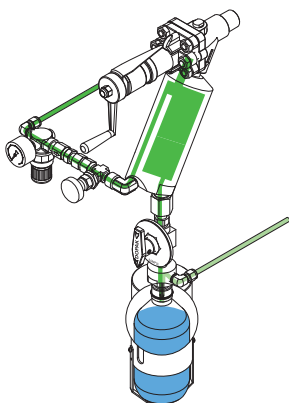

**2 - sample**

Open the purge valve and the block valve between needle assembly and jet purge adapter. The inert gas will assist the sample into the bottle and will purge the sampler. This position can be held for any required time.

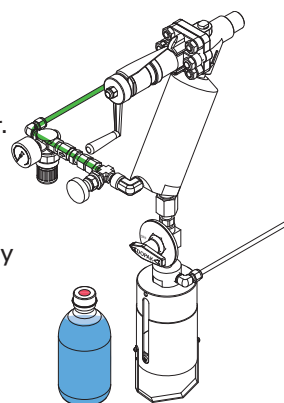

**3 - off**

Close the purge valve. Remove the bottle retaining clip and pull the bottle out from the sleeve. The septum reseals automatically.

**2 TYPICAL P & ID**

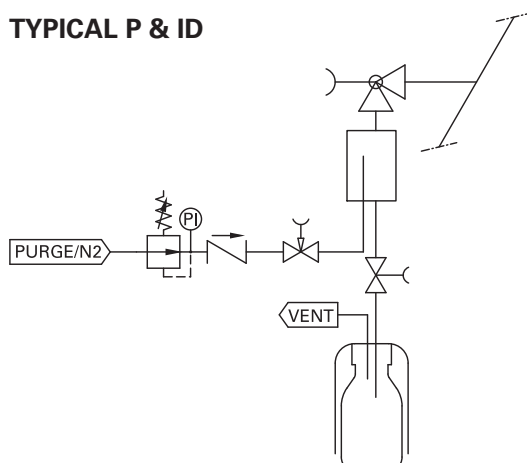

Fixed volume (C2)



### 3 FEATURES/ADVANTAGES/PROPERTIES

- Sampling independent of process conditions
- High pressure and vacuum applications
- Representative sampling
- Zero dead volume
- Closed sampling
- Fixed volume sampling
- Purging of sampler
- Retrofittable to valve

### 4 BASIC SPECIFICATIONS

<b>Material</b>	SS316, SS316L.
<b>Sleeve type</b>	60cc sleeve with bottle retaining clip.
<b>Needle assembly</b>	Single piece VTO needle assembly with vent to outlet connection 1/4" FNPT. Process/vent needle ID: 1.35 mm.
<b>Valve</b>	Piston valve. PTFE seats. Pressure range ANSI B16.34. Temperature range -29/+232°C (-20/+450°F).
<b>Operation</b>	Manual.
<b>Connections</b>	Process: 3/4" MNPT Vent: 1/4" FNPT Purge: 1/4" FNPT, needle valve, regulator, gauge and check valve included.
<b>Please note:</b>	the above is a basic specification only. DOPAK® Samplers can be offered with a wide variety of options as mentioned below.



### 5 OPTIONS

- Heating/cooling jacket
- Solvent purge facility
- Lockable handle
- Mounting plate
- Pipe stand
- Block valve
- Enclosure
- Mounting bracket
- Steam sterilising cap
- Exotic materials

For more information please refer to our sheets:

**Options for DOPAK® process samplers, sampling into a bottle.**

**Components for DOPAK® process samplers.**

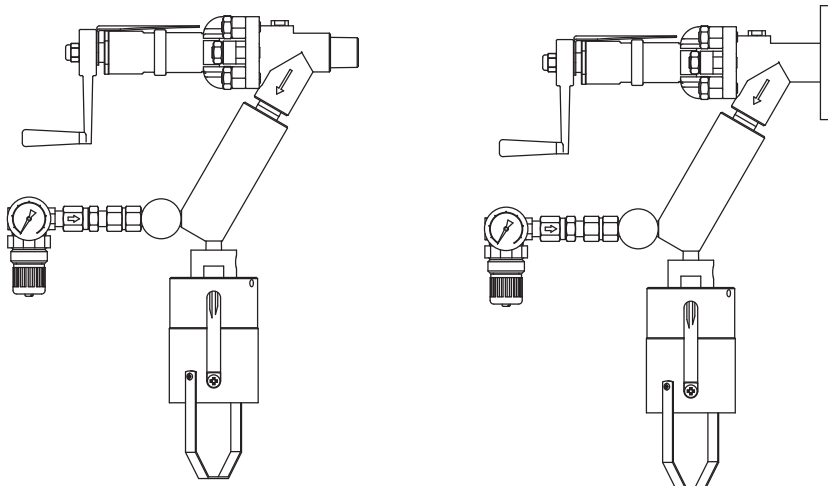

#### Dopak Inc.

Houston, Texas 77041, USA  
Phone 713-460-8311  
Fax 713-460-8578  
E-mail info@dopak.com

#### Dovianus BV

Bergschenhoek, The Netherlands  
Phone +31 10 524 20 00  
Fax +31 10 456 67 74  
E-mail info@dopak.nl

Your local representative:

