

DOPAK® Process Sampler Type S32

back purge configuration with vacuum connection

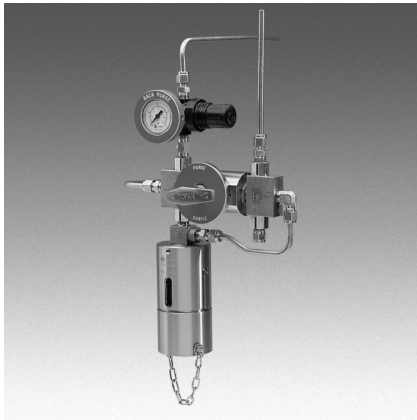

The ability to create a vacuum in the sample bottle by a connection to a vacuum source ensures optimal retrieval of a representative, contamination free sample from processes at vacuum conditions or atmospheric pressure. The S32 type of sampler in back purge configuration allows a gas to purge the sampler and process connection prior to sampling ensuring a fresh sample. All S32 type of samplers offer a one-handle operation by multiple valves.

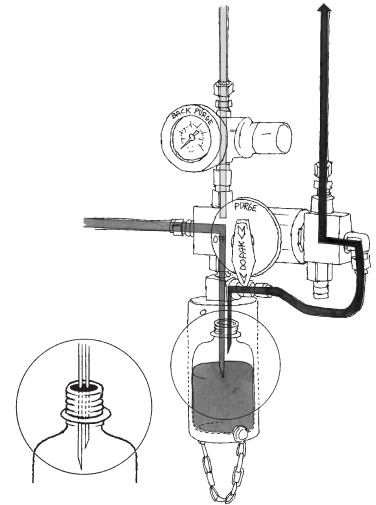

1 OPERATION/FUNCTION

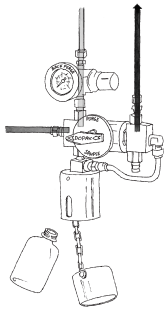

0 - off

Provide a new septum on your sample bottle. Insert the bottle, with cap and septum into the bottom part of the bayonet sleeve. Connect the bottom part of the bayonet sleeve to the upper-part, move the bottom part upwards and lock it by turning it in the slot, in the top end position.

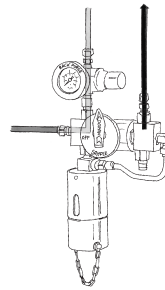

1 - back purge

Turn the handle to the "back purge" position, allowing a flow of purge gas through the sampler to the process to ensure representative sampling. This position can be held for any required time.

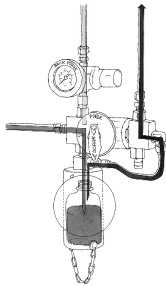

2 - sample

Turn the handle to the "sample" position, allowing the vacuum to be connected to the vent outlet of the needle assembly to create a vacuum in the sample bottle. The sample flows into the sample bottle. When the required amount has been taken, turn the handle into the "off" position.

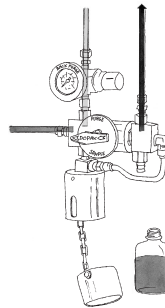

3 - off

Move the bottom part of the bayonet sleeve slightly upwards, turn it and pull it out from the upper part. The septum reseals automatically. Take the bottle out from the bottom part of the bayonet sleeve.

2 TYPICAL P & ID

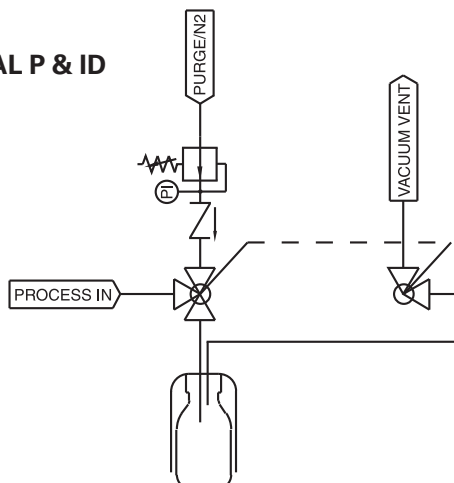

3 FEATURES/ADVANTAGES/PROPERTIES

- | | | | |
|--------------------------|--|--------------------------|------------------------------------|
| <input type="checkbox"/> | Sampling directly under process conditions | <input type="checkbox"/> | Closed sampling |
| <input type="checkbox"/> | Atmospheric and vacuum applications | <input type="checkbox"/> | One handle operation |
| <input type="checkbox"/> | Representative sampling | <input type="checkbox"/> | Purging of sampler |
| <input type="checkbox"/> | Zero dead volume | <input type="checkbox"/> | Positive vent/vacuum line shut off |

4 BASIC SPECIFICATIONS

Material	SS316, SS316L.	
Sleeve Type	60cc bayonet sleeve.	
Needle Assembly	Single piece VTO needle assembly with TTC ring and vent to outlet connection 1/4" FNPT. Process/vent needle ID:1.35 mm.	
Valves	<p>Process: Three-way ball valve type W83. PTFE seats, Viton A O-rings. Pressure range 103 bar @ 20°C (1500 psig @ 70°F).</p> <p>Vent: Two-way ball valve type W83. PTFE seats, Pressure range 206 bar @ 20°C (3000 psi @ 70°F).</p> <p>Temperature range -17/+232°C (0/+450°F).</p>	
Operation	Manual by gearbox.	
Connections	1/4" FNPT, regulator, gauge and check valve included.	

Please note: the above is a basic specification only. DOPAK® Samplers can be offered with a wide variety of options as mentioned below.

5 OPTIONS

- | | | | |
|--------------------------|----------------------|--------------------------|----------------------------|
| <input type="checkbox"/> | Spring return handle | <input type="checkbox"/> | Sample cooler |
| <input type="checkbox"/> | Lockable handle | <input type="checkbox"/> | Mounting bracket |
| <input type="checkbox"/> | Mounting plate | <input type="checkbox"/> | Steam sterilising cap |
| <input type="checkbox"/> | Pipe stand | <input type="checkbox"/> | Welded connection |
| <input type="checkbox"/> | Block valve | <input type="checkbox"/> | Exotic materials |
| <input type="checkbox"/> | Flow meter | <input type="checkbox"/> | Larger/smaller sample size |
| <input type="checkbox"/> | Enclosure | | |

For more information please refer to our sheets:

Options for DOPAK® process sampler type S32.

Components for DOPAK® process samplers.

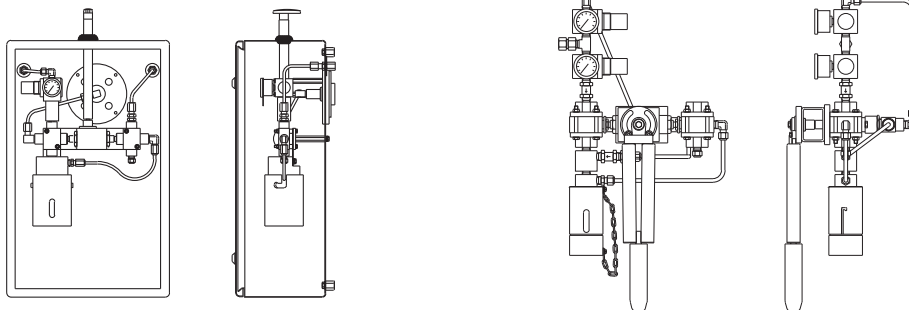

Dopak Inc.
Houston, Texas 77041, USA
Phone 713-460-8311
Fax 713-460-8578
E-mail info@dopak.com

Dovianus BV
Bergschenhoek, The Netherlands
Phone +31 10 542 20 00
Fax +31 10 456 67 74
E-mail info@dopak.nl

Your local representative: