

DOPAK® Process Sampler Type S32

overflow vacuum configuration

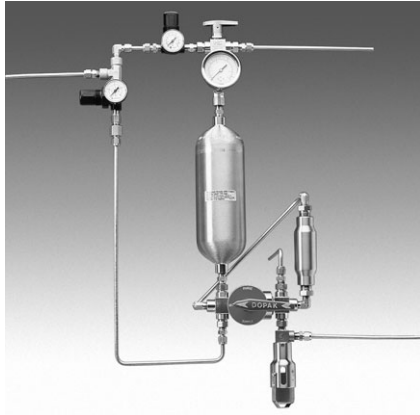

The ability to purge the sample point ensures optimal retrieval of a representative, contamination free sample. The S32 type sampler in overflow vacuum configuration provides a system purge to an overflow chamber and needle purge in addition to a fixed sample. The unique design offers a one-handle operation by multiple valves, allowing for sampling reactors and vessels at atmospheric or vacuum conditions.

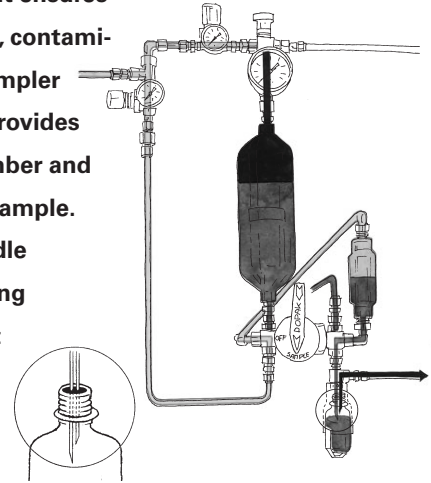

1 OPERATION/FUNCTION

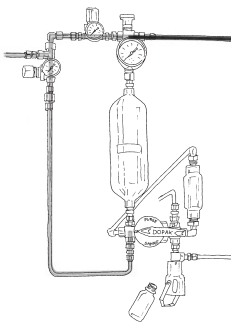

0 - off

Provide a new septum on your sample bottle. Insert the sample bottle, with cap and septum into the sleeve until the septum is pierced by the needles. Put the bottle retaining clip in place.

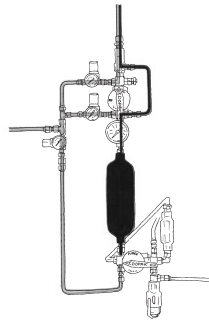

1 - vacuum

Turn the handle on top of the overflow chamber to the "vacuum" position, allowing a vacuum to be created in the overflow chamber.

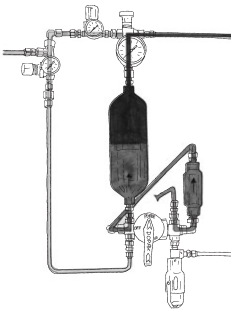

2 - system purge

Turn the main handle to the "purge" position, allowing the vacuum to be connected to the process, creating a flow of liquid through the sample chamber into the overflow chamber to ensure representative sampling.

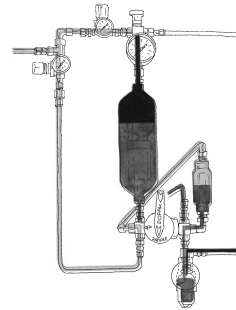

3 - sample

Turn the main handle to the "sample" position allowing the product to flow into the sample bottle. The fixed volume chamber determines the amount of sample. The inert gas will assist the sample to flow into the bottle and will purge the sampler. This position can be held for any required time.

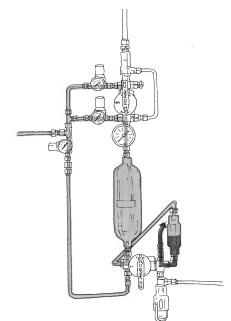

4 - back purge

Turn the main handle and the handle on top of the overflow chamber both to the "purge" position, allowing an inert gas to back purge the residue material to the process connection. This position can be held for any required time.

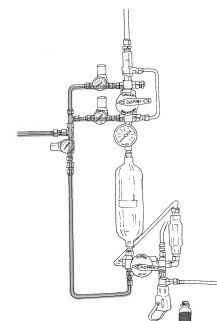

5 - off

Turn all handles to the "off" position. Remove the bottle retaining clip and pull the bottle out from the sleeve. The septum reseals automatically. Put a new bottle in place.



2 TYPICAL P & ID

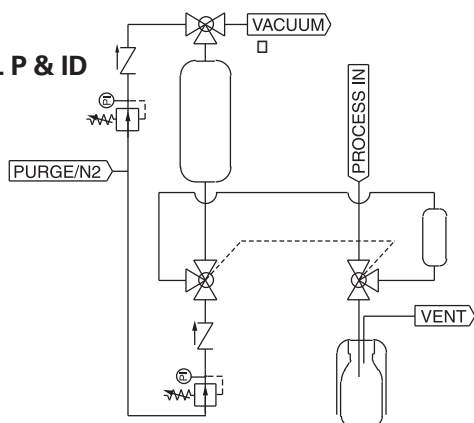

3 FEATURES/ADVANTAGES/PROPERTIES

- Atmospheric and vacuum applications
- Representative sampling
- Zero dead volume
- Closed sampling
- One handle operation
- Fixed volume sampling
- Purging of sampler

4 BASIC SPECIFICATIONS

Material	SS316, SS316L.	
Sleeve Type	60cc sleeve with bottle retaining clip.	
Needle Assembly	Single piece VTO needle assembly with vent to outlet and vent to outlet connection 1/4" FNPT. Process/vent needle ID: 1.35 mm.	
Sample Chamber	50cc.	
Valve	Three-way ball valve type W83. PTFE seats. Viton A O-rings. Pressure range 103 bar @ 20°C (1500 psig @ 70°F). Temperature range -17°C/+232°C (0°F/+450°F).	
Operation	Manual.	
Connections	1/4" FNPT, regulator, gauge and check valve included.	

Please note: the above is a basic specification only. Dopak Samplers can be offered with a wide variety of options as mentioned below.

5 OPTIONS

- | | |
|---|---|
| <input type="checkbox"/> Spring return handle | <input type="checkbox"/> Enclosure |
| <input type="checkbox"/> Lockable handle | <input type="checkbox"/> Sample cooler |
| <input type="checkbox"/> Mounting plate | <input type="checkbox"/> Mounting bracket |
| <input type="checkbox"/> Pipe stand | <input type="checkbox"/> Continuous needle purge |
| <input type="checkbox"/> Block valve | <input type="checkbox"/> Exotic materials |
| <input type="checkbox"/> Flow meter | <input type="checkbox"/> Larger/smaller sample size |

For more information please refer to our sheets:
Options for DOPAK® process sampler type S32.
Components for DOPAK® process samplers.

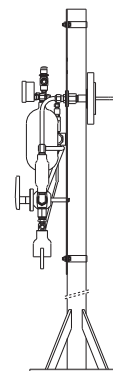
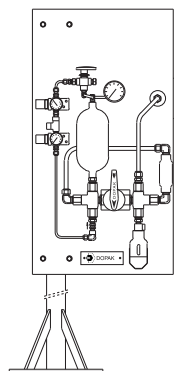

Dopak Inc.

Houston, Texas 77041, USA
 Phone 713-460-8311
 Fax 713-460-8578
 E-mail info@dopak.com

Dovianus BV

Bergschenhoek, The Netherlands
 Phone +31 10 524 20 00
 Fax +31 10 456 67 74
 E-mail info@dopak.nl

Your local representative: