

DOPAK® Process Sampler Type S32-LG

purge expansion configuration

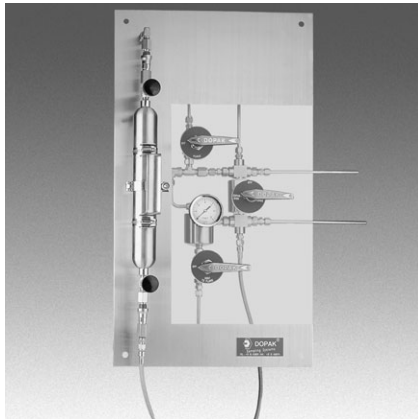

The ability to purge the sample point ensures optimal retrieval of a representative, contamination free sample. The S32-LG type samplers provide a system purge in addition to sampling in a sample cylinder with a predefined filling rate. This is achieved by using an expansion chamber. The system is equipped with an extra valve on the expansion chamber to enable purging of the expansion chamber with an inert gas for product with a boiling point around atmospheric conditions. The unique design offers a one handle operation by multiple valves.

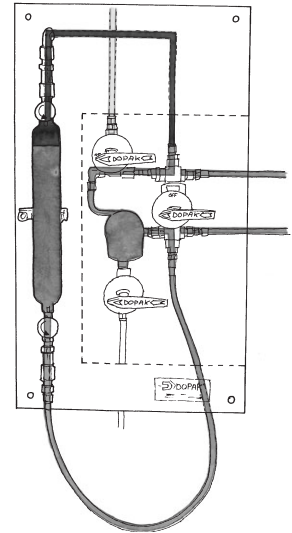

1 OPERATION/FUNCTION

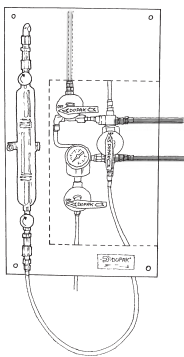

0 - off
Install the sample cylinder and connect the flexible hose to the bottom side of the sample cylinder. Open the needle valves of the sample cylinder.

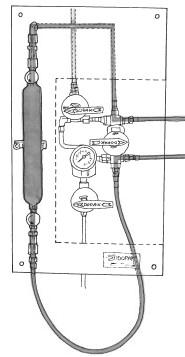

1 - system purge
Turn the handle to the "process" position, allowing the sample cylinder to be filled. To ensure representative sample, this position can be held for any required time.

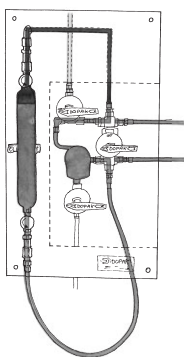

2 - expansion
Turn the handle to the "expansion" position. The internal connection between the sample cylinder and the expansion chamber has now been made. Maintain this position for any required time to enable the fluid to divide over the sample cylinder and expansion chamber. Close the two needle valves of the sample cylinder.

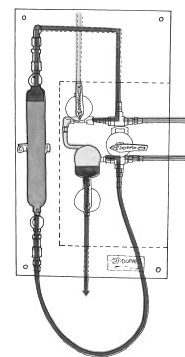

3 - vent/purge
Open the valve on the expansion chamber and the valve in the purge line. The expansion chamber and quick connects are being depressurised to the vent system and purged with an inert gas. Close both valves by releasing the handles.

2 TYPICAL P & ID

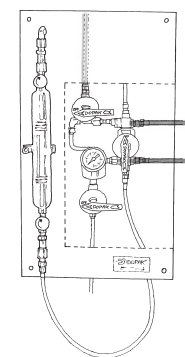
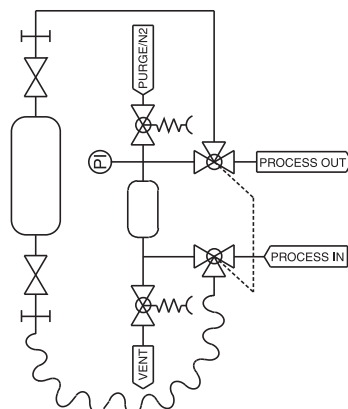

4 - off
Turn the handle to the "off" position. Disconnect the flexible hose. Remove the sample cylinder and connect the flexible hose to the top quick connect.



3 FEATURES/ADVANTAGES/PROPERTIES

- | | |
|--|---|
| <input type="checkbox"/> Sampling in cylinder with predefined filling rate | <input type="checkbox"/> Fixed volume sampling |
| <input type="checkbox"/> Representative sampling | <input type="checkbox"/> Purging of sampler |
| <input type="checkbox"/> Zero dead volume | <input type="checkbox"/> No direct connection between vent line and process lines |
| <input type="checkbox"/> Closed sampling | <input type="checkbox"/> Depressurising of quick connect couplings |
| <input type="checkbox"/> One handle operation of mutiple valves | <input type="checkbox"/> No outage tubes |

4 BASIC SPECIFICATIONS

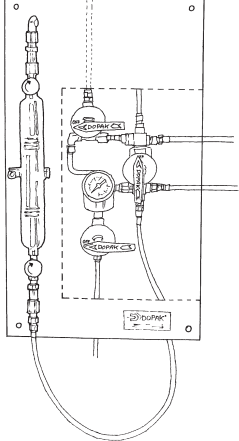
Material	SS316, SS316L.	
Cylinder Type	500cc cylinder.	
Expansion Chamber	75cc (15% of sample volume).	
Valve	Three-way ball valve type W83. PTFE seats, Viton A O-rings. Pressure range 103 bar @ 20°C (1500 psig @ 70°F). Temperature range -17/+232°C (0/+450°F).	
Operation	Manual.	
Connections	1/4" FNPT.	

Please note: the above is a basic specification only. DOPAK® Samplers can be offered with a wide variety of options as mentioned below.

5 OPTIONS

- | | |
|---|---|
| <input type="checkbox"/> Spring return handle | <input type="checkbox"/> Enclosure |
| <input type="checkbox"/> Lockable handle | <input type="checkbox"/> Sample cooler |
| <input type="checkbox"/> Pipe stand | <input type="checkbox"/> Exotic materials |
| <input type="checkbox"/> Block valve | <input type="checkbox"/> Larger/smaller sample size |
| <input type="checkbox"/> Flow meter | |

For more information please refer to our sheets:
Options for DOPAK® process sampler type S32-LG.
Components for DOPAK® process samplers.

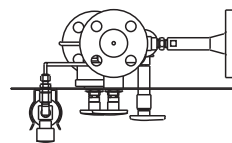
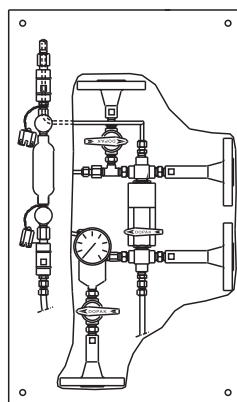
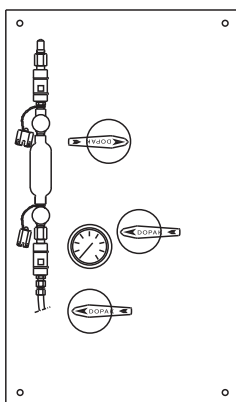

Dopak Inc.
Houston, Texas 77041, USA
Phone 713-460-8311
Fax 713-460-8578
E-mail info@dopak.com

Dovianus BV
Bergschenhoek, The Netherlands
Phone +31 10 524 20 00
Fax +31 10 456 67 74
E-mail info@dopak.nl

Your local representative: