

DOPAK® Process Sampler Type DPJ

solvent purge configuration

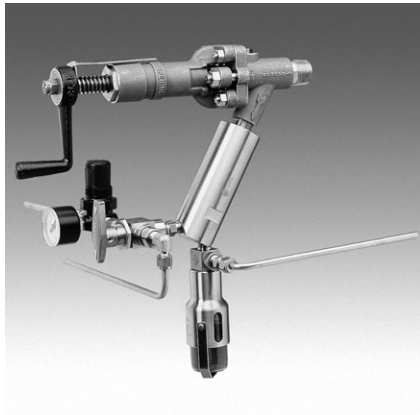

Being able to provide a jet purge adapter to a piston type sampling valve, ensures optimal retrieval of a representative, contamination free sample of high viscosity liquids. The DPJ type sampler allows purging of the sample valve outlet thus eliminating dead volume. In solvent purge configuration, the system allows for purging with a solvent or with nitrogen.

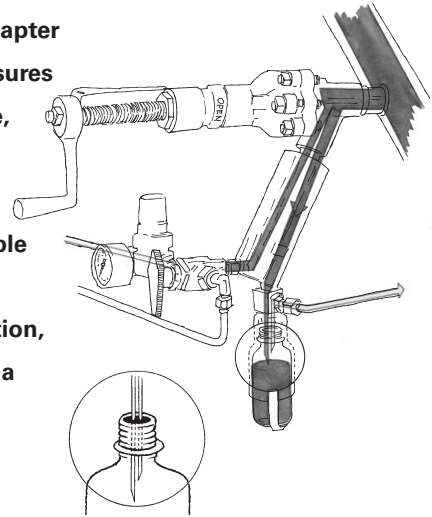

1 OPERATION/FUNCTION

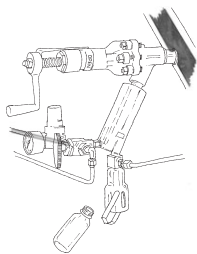

0 - off
Provide a new septum on your sample bottle. Insert the bottle, with cap and septum into the sleeve until the needles pierce the septum. Put the bottle retaining clip in place.

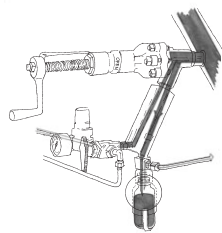

1 - sample
Open the piston valve allowing the product to flow into the sample bottle. When the required amount has been taken, close the valve.

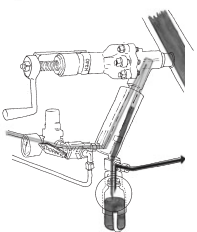

2 - nitrogen purge
Turn the valve in the purge line to nitrogen, allowing a flow of purge gas through the sampler to ensure any residual liquid is forced into the sample bottle. This position can be held for any required time.

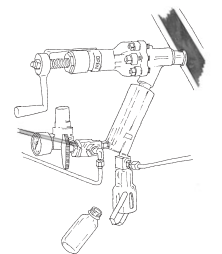

3 - off
Close the valve in the purge line, remove the bottle retaining clip and pull the bottle out from the sleeve. The septum reseals automatically.

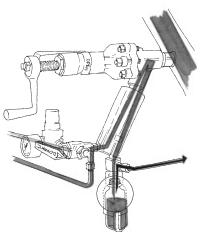

4 - solvent purge
Put a new bottle in place. Turn the valve in the purge line to solvent, allowing a flow of solvent through the sampler into the sample bottle.

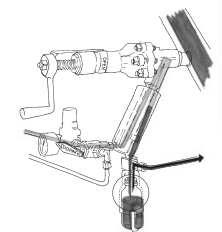

5 - nitrogen needle purge
Turn the valve in the purge line to nitrogen, allowing a flow of purge gas through the sampler to ensure any residual solvent is forced into the sample bottle. This position can be held for any required time.

2 TYPICAL P & ID

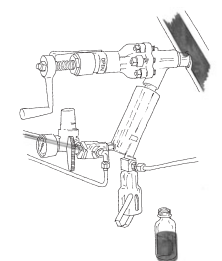
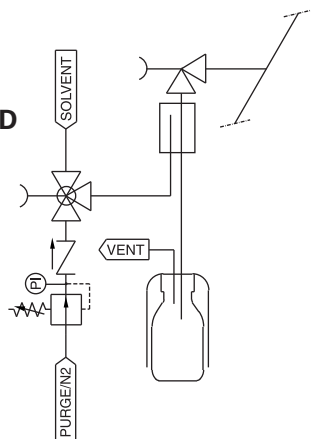

6 - off
Close the valve in the purge line, remove the bottle retaining clip and pull the bottle out from the sleeve. The septum reseals automatically.



3 FEATURES/ADVANTAGES/PROPERTIES

- | | | | |
|--------------------------|--|--------------------------|---|
| <input type="checkbox"/> | Sampling directly under process conditions | <input type="checkbox"/> | Closed sampling |
| <input type="checkbox"/> | Low pressure applications | <input type="checkbox"/> | High viscosity sampling |
| <input type="checkbox"/> | Representative sampling | <input type="checkbox"/> | Purging of sampler with gas and solvent |
| <input type="checkbox"/> | Zero dead volume | <input type="checkbox"/> | Retrofittable to valve |

4 BASIC SPECIFICATIONS

| | | |
|------------------------|---|--|
| Material | SS316, SS316L. | |
| Sleeve Type | 60cc sleeve with bottle retaining clip. | |
| Needle Assembly | Single piece VTO needle assembly with vent to outlet connection 1/4" FNPT. Process/vent needle ID: 1.35 mm. | |
| Valves | Piston valve. PTFE seats. Pressure range ANSI B16.34. Temperature range -29/+232°C (-20/+450°F). | |
| Operation | Manual. | |
| Connections | Process: 3/4" MNPT Vent: 1/4" FNPT Purge: 1/4" FNPT, needle valve, regulator, gauge and check valve included. | |

Please note: the above is a basic specification only. Dopak Samplers can be offered with a wide variety of options as mentioned below.

5 OPTIONS

- | | | | |
|--------------------------|------------------------|--------------------------|----------------------------|
| <input type="checkbox"/> | Fixed volume chamber | <input type="checkbox"/> | Enclosure |
| <input type="checkbox"/> | Heating/cooling jacket | <input type="checkbox"/> | Steam sterilising cap |
| <input type="checkbox"/> | Mounting plate | <input type="checkbox"/> | Mounting bracket |
| <input type="checkbox"/> | Pipe stand | <input type="checkbox"/> | Exotic materials |
| <input type="checkbox"/> | Block valve | <input type="checkbox"/> | Larger/smaller sample size |
| <input type="checkbox"/> | Flow meter | | |

For more information please refer to our sheets:

Options for DOPAK® process sampler type DPJ.
Components for DOPAK® process samplers.

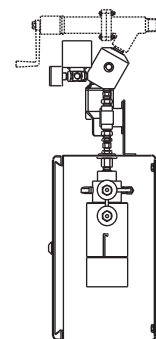
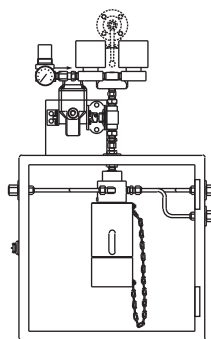
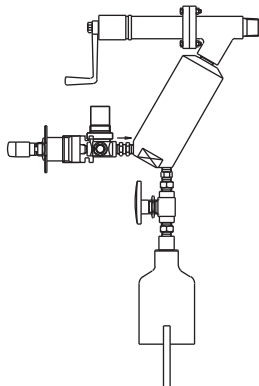
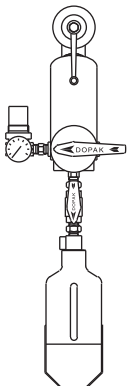

Dopak Inc.
Houston, Texas 77041, USA
Phone 713-460-8311
Fax 713-460-8578
E-mail info@dopak.com

Dovianus BV
Bergschenhoek, The Netherlands
Phone +31 10 524 20 00
Fax +31 10 456 67 74
E-mail info@dopak.nl

Your local representative:

