

DOPAK® Process Sampler Type S23

with welded connections

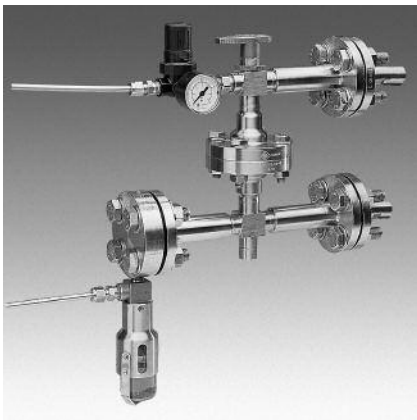

The ability to purge the sample point ensures optimal retrieval of a representative, contamination free sample. The S23 type sampler provides a system purge and needle purge in addition to a fixed sample volume.

The unique design offers a one-handle operation of multiple valves, allowing for sampling independent of the process conditions. These features provide sample accuracy and safety.

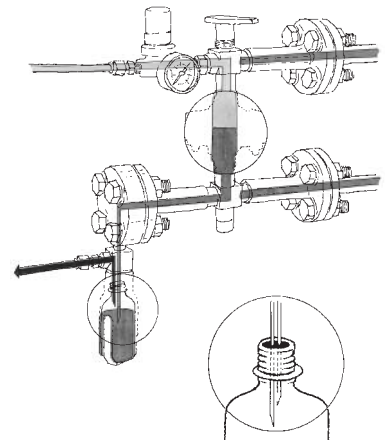

1 OPERATION/FUNCTION

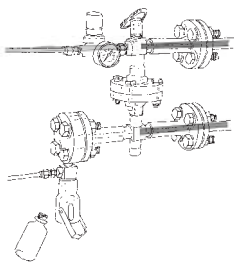

0 - off

Provide a new septum on your sample bottle. Insert the bottle, with cap and septum into the sleeve until the septum is pierced by the needles. Put the bottle retaining clip in place.

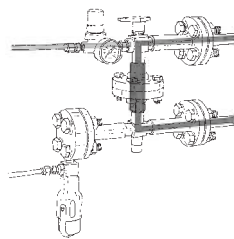

1 - system purge

Turn the handle to the "purge" position, allowing a continuous flow of liquid through the sampler to ensure representative sampling. This position can be held for any required time.

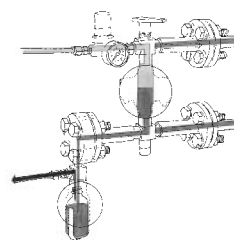

2 - sample

Turn the handle to the "sample" position, allowing the product to flow into the sample bottle. The fixed volume sample chamber determines the amount of sample. The inert gas will assist the sample to flow into the bottle and will purge the sampler. This position can be held for any required time.

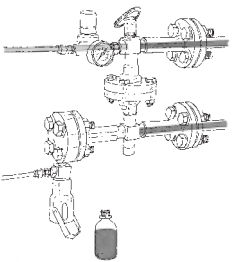

3 - off

Turn the handle to the "off" position. Remove the bottle retaining clip and pull the bottle out from the sleeve. The septum reseals automatically.

2 TYPICAL P & ID

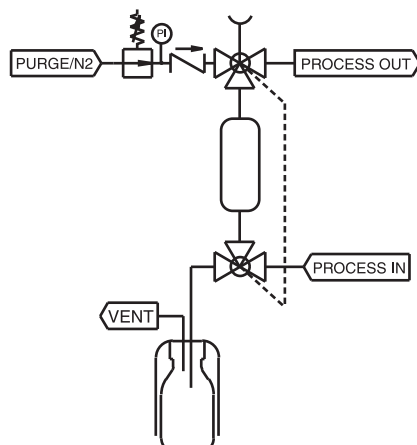

3 FEATURES/ADVANTAGES/PROPERTIES

- | | | | |
|--------------------------|--|--------------------------|------------------------|
| <input type="checkbox"/> | Sampling independent of process conditions | <input type="checkbox"/> | Closed sampling |
| <input type="checkbox"/> | High pressure and vacuum applications | <input type="checkbox"/> | One handle operation |
| <input type="checkbox"/> | Representative sampling | <input type="checkbox"/> | Fixed volume sampling |
| <input type="checkbox"/> | Zero dead volume | <input type="checkbox"/> | Purging of the sampler |

4 BASIC SPECIFICATIONS

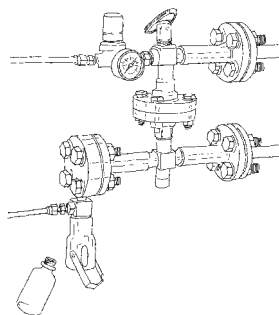
Material	SS316, SS316L.	
Sleeve Type	60cc sleeve with bottle retaining clip.	
Needle Assembly	Single piece VTO needle assembly with vent to outlet connection 1/4" FNPT. Process/vent needle ID: 1.35 mm.	
Sample Chamber	50cc.	
Valve	Three-way ball valve type W83. PTFE seats, Viton A O-rings. Pressure range 103 bar @ 20°C (1500 psig @ 70°F). Temperature range -17/+232°C (0/+450°F).	
Operation	Manual.	
Connections	Regulator, gauge and check valve included.	

Please note: the above is a basic specification only. DOPAK® Samplers can be offered with a wide variety of options as mentioned below.

5 OPTIONS

- | | | | |
|--------------------------|----------------------|--------------------------|----------------------------|
| <input type="checkbox"/> | Spring return handle | <input type="checkbox"/> | Sample cooler |
| <input type="checkbox"/> | Lockable handle | <input type="checkbox"/> | Mounting bracket |
| <input type="checkbox"/> | Mounting plate | <input type="checkbox"/> | Steam sterilising cap |
| <input type="checkbox"/> | Pipe stand | <input type="checkbox"/> | Threaded connections |
| <input type="checkbox"/> | Block valve | <input type="checkbox"/> | Continuous needle purge |
| <input type="checkbox"/> | Flow meter | <input type="checkbox"/> | Exotic materials |
| <input type="checkbox"/> | Enclosure | <input type="checkbox"/> | Larger/smaller sample size |
| <input type="checkbox"/> | Steam jacket | | |

For more information please refer to our sheets:

Options for DOPAK® process sampler type S23. Components for DOPAK® process samplers.

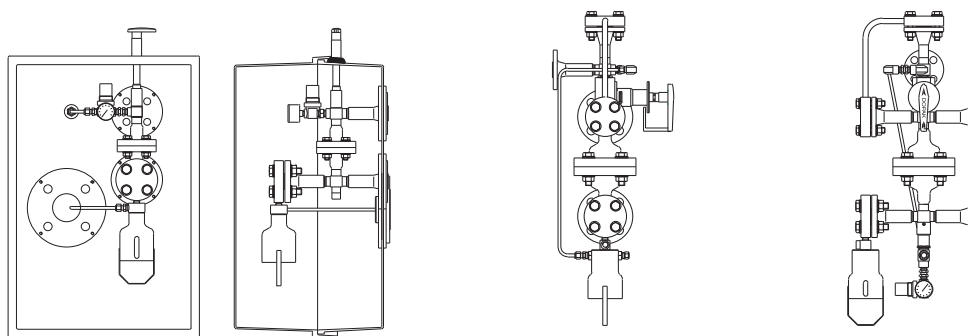

Dopak Inc.
Houston, Texas 77041, USA
Phone 713-460-8311
Fax 713-460-8578
E-mail info@dopak.com

Dovianus BV
Bergschenhoek, The Netherlands
Phone +31 10 542 20 00
Fax +31 10 456 67 74
E-mail info@dopak.nl

Your local representative: