

DOPAK® Process Sampler Type S32-LG vent to flare configuration (F2)

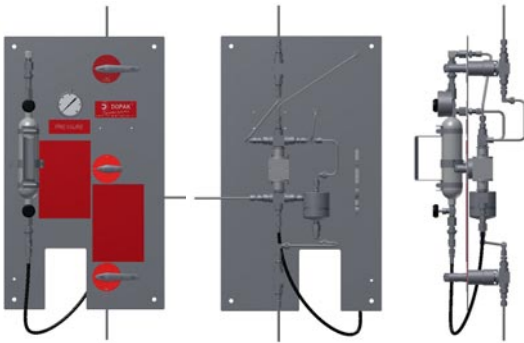

The ability to purge the sample point ensures optimal retrieval of a representative, contamination free sample. The S32-LG type samplers provide a system purge in addition to sampling in a sample cylinder with a predefined filling rate. This is achieved by using an expansion chamber. This system is equipped with an additional valve on the process outlet in order to ensure filling of the cylinder with liquid when difference between inlet and outlet pressure is significant. The unique design offers a one handle operation by multiple valves.

This sampler type is suitable for liquefied gases and liquids.

1 OPERATION/FUNCTION

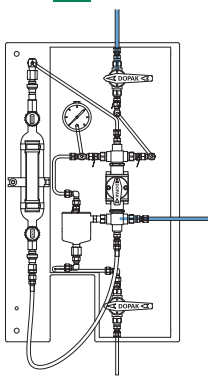

0 - off

Install the sample cylinder and connect the flexible hose to the bottom side of the sample cylinder. Open the needle valves of the sample cylinder.

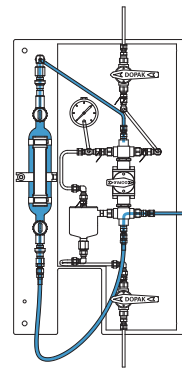

1 - pressurise

Turn the handle to the "process" position, allowing the sample cylinder to be filled and the system to be pressurised.

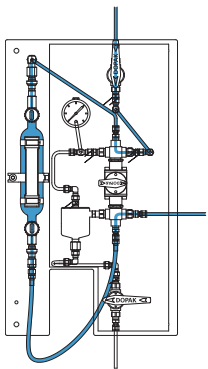

2 - system purge

Open the valve on the process outlet to allow a flow of liquid through the sample cylinder. To ensure a representative sample this position can be held for any required time. Close the valve on the process outlet by releasing the handle.

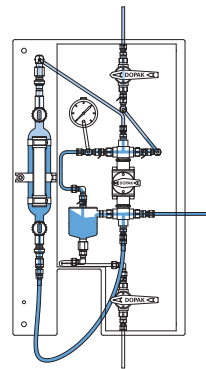

3 - expansion

Turn the handle to the "expansion" position. The internal connection between the sample cylinder and the expansion chamber has now been made. Maintain this position for any required time to enable the fluid to divide over the sample cylinder and expansion chamber. Close the two needle valves of the sample cylinder.

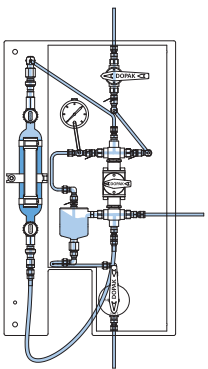

4 - vent

Open the valve on the expansion chamber. The expansion chamber and quick connects are being depressurised to the vent system. Release the handle to close the valve.

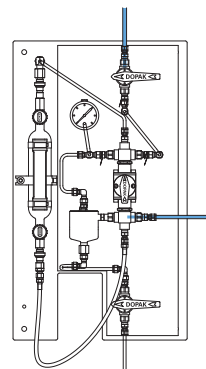

5 - off

Turn the handle to the "off" position. Disconnect the flexible hose. Remove the sample cylinder and connect the flexible hose to the top quick connect coupling.



2 TYPICAL P & ID

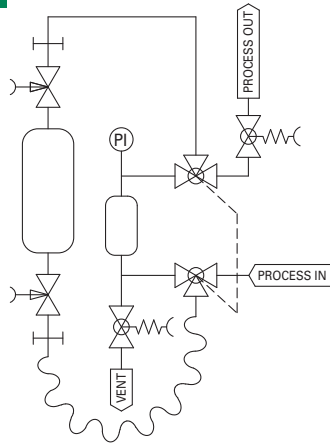

vent to flare configuration (F2)

3 FEATURES/ADVANTAGES/PROPERTIES

- Sampling in cylinder with predefined filling rate
- Representative sampling
- Zero dead volume
- Closed sampling
- One handle operation of mutple valves
- Fixed volume sampling
- Purging of sampler
- No direct connection between vent line and process lines
- Depressurissation of quick connect couplings before disconnection
- No outage tube needed

4 BASIC SPECIFICATIONS

Material	SS316, SS316L.
Cylinder Type	500cc cylinder.
Expansion Chamber	100cc (20% of sample volume).
Valve	Three-way ball valve type W83. PTFE seats, Viton A O-rings. Pressure range 103 bar @ 20°C (1500 psig @ 70°F). Temperature range -17/+232°C (0/+450°F).
Operation	Manual.
Connections	1/4" FNPT. Regulator, pressure gauge and check valve included.
Please note:	the above is a basic specification only. DOPAK® Samplers can be offered with a wide variety of options as mentioned below.

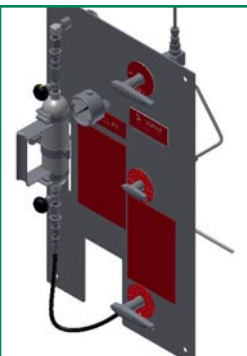

5 OPTIONS

- Spring return handle
- Lockable handle
- Pipe stand
- Block valve
- Flow meter
- Enclosure
- Sample cooler
- Exotic materials
- Larger/smaller sample size

For more information please refer to our sheets:

Options for DOPAK® process sampler, sampling into a cylinder.

Components for DOPAK® process samplers.

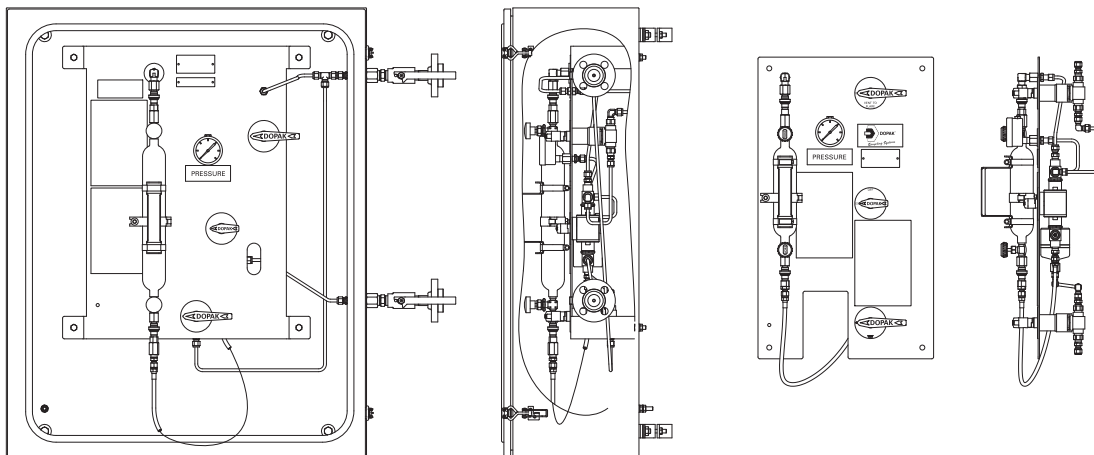

Dopak Inc.

Houston, Texas 77041, USA
 Phone 713-460-8311
 Fax 713-460-8578
 E-mail info@dopak.com

Dovianus BV

Bergschenhoek, The Netherlands
 Phone +31 10 524 20 00
 Fax +31 10 524 20 29
 E-mail info@dopak.nl

Your local representative:

