

DOPAK® Process Sampler Type DPM

inline, continuous needle purge configuration (A8)

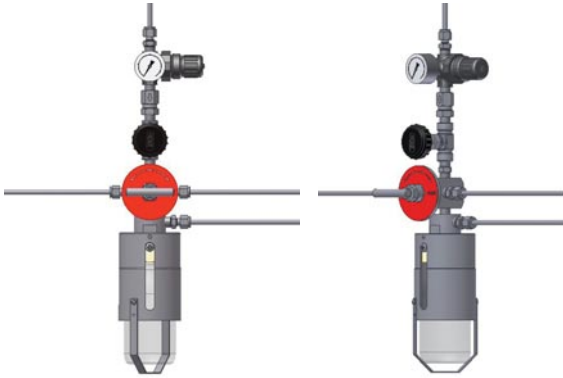

The ability to purge the needle assembly, both before and after sampling, ensures there is no residue build up in the needle assembly after retrieval of a representative, contamination free sample. The DPM type of sampler in an inline needle purge configuration allows product to flow directly into the sampler via an inline sample valve.

1 OPERATION/FUNCTION

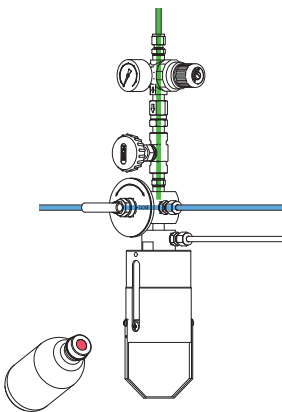

0 - off

Provide a new septum on your sample bottle. Insert the sample bottle, with cap and septum into the sleeve until the septum is pierced by the needles. Put the bottle retaining clip in place.

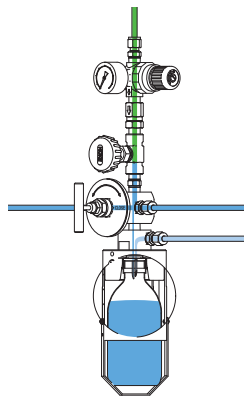

1 - sample

Open the valve in the process line, allowing the product to flow into the sample bottle. When the required amount has been taken, close the valve.

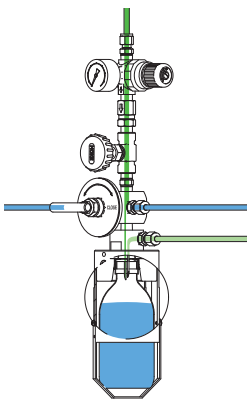

2 - needle purge

Open the valve in the purge line allowing a flow of gas through the sampler to ensure any residual liquid is forced into the sample bottle. This position can be held for any required time. Close the valve.

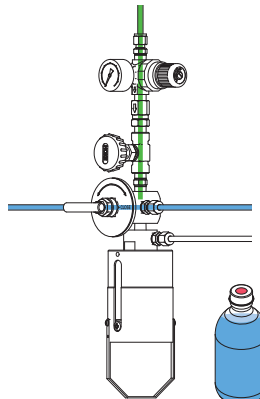

3 - off

Remove the bottle retaining clip and pull the bottle out from the sleeve. The septum reseals itself automatically.

2 TYPICAL P & ID

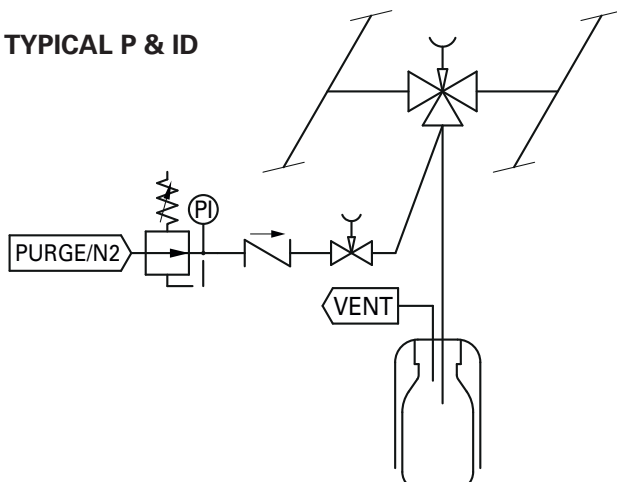

3 FEATURES/ADVANTAGES/PROPERTIES

- Sampling directly under process conditions
- Low/elevated pressure applications
- Representative sampling
- Zero dead volume
- Closed sampling
- No build up of sample material in the needle assembly
- Inertizing of bottle

4 BASIC SPECIFICATIONS

Material	SS316, SS316L.
Sleeve type	60cc sleeve with bottle retaining clip.
Needle assembly	Single piece VTO needle assembly with vent to outlet connection 1/4" FNPT. Process/vent needle ID: 1.35 mm.
Valve	In line valve. Pressure range 206 bar @ 20°C (3000 psig @ 70°F). Temperature range -20/+230°C (-4/+446°F).
Operation	Manual.
Connections	Process: 1/4" FNPT. Purge: 1/4" FNPT, regulator, gauge and check valve included. Vent: 1/4" FNPT.
Please note:	the above is a basic specification only. DOPAK® Samplers can be offered with a wide variety of options as mentioned below.



5 OPTIONS

- Lockable handle
- Enclosure
- Steam sterilising cap
- Exotic materials
- Solvent purge facility
- Larger/smaller sample size

For more information please refer to our sheets:

Options for DOPAK® process samplers, sampling into a bottle.

Components for DOPAK® process samplers.

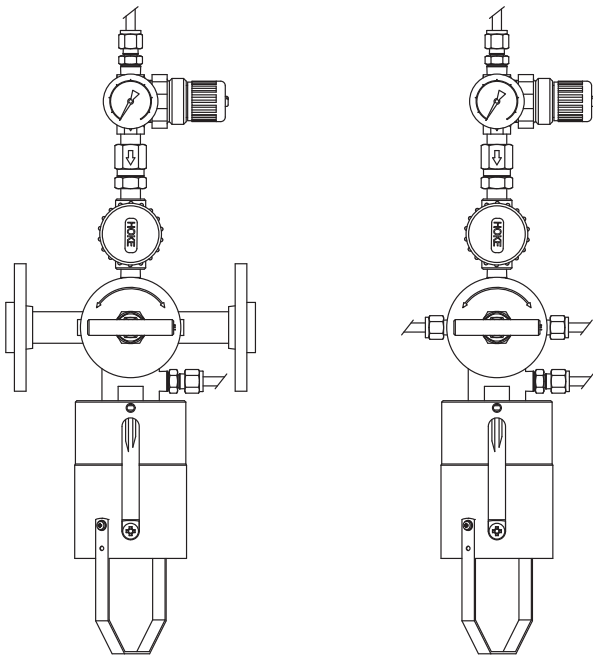

Dopak PFT Corp.

Houston, Texas 77041, USA

Phone 713-460-8311

Fax 713-460-8578

E-mail info-dopak@cranecpe.com

Dovianus BV

Bergschenhoek, The Netherlands

Phone +31 10 524 20 00

Fax +31 10 524 20 29

E-mail info-dovianus@cranecpe.com

Your local distributor

